

# Technical data sheet



## Product features

### Lava stone grill gas 2 cooking areas 2x 52x36 on open cabinet

<b>Model</b>	<b>SAP Code</b>	00110079
GL 70/80 G	<b>A group of articles - web</b>	Grills and grill plates



- Griddle dimensions [mm x mm]: 520 x 380
- Container for liquid fat: Yes
- Ignition: Piezo + večný plamen

<b>SAP Code</b>	00110079	<b>Net Weight [kg]</b>	69.00
<b>Net Width [mm]</b>	800	<b>Power gas [kW]</b>	13.000
<b>Net Depth [mm]</b>	700	<b>Type of gas</b>	Natural gas, propane butane
<b>Net Height [mm]</b>	1004	<b>Griddle dimensions [mm x mm]</b>	520 x 380

# Technical data sheet



Technical drawing

Lava stone grill gas 2 cooking areas 2x 52x36 on open cabinet

<b>Model</b>	<b>SAP Code</b>	00110079
GL 70/80 G	<b>A group of articles - web</b>	Grills and grill plates

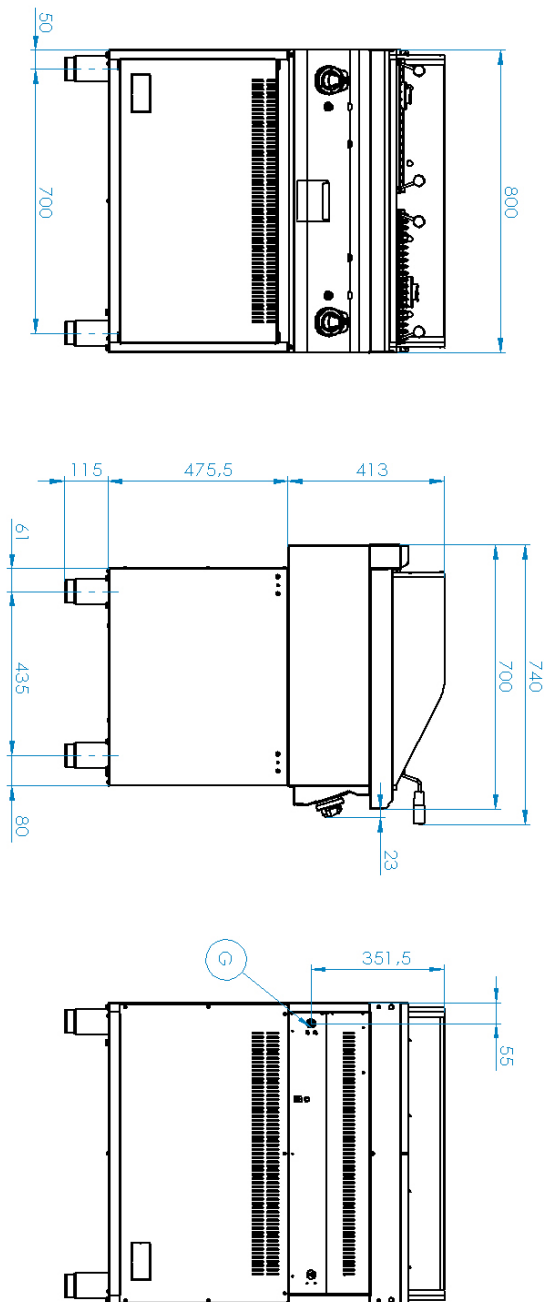

# Technical data sheet



## Product benefits

### Lava stone grill gas 2 cooking areas 2x 52x36 on open cabinet

<b>Model</b>	<b>SAP Code</b>	00110079
GL 70/80 G	<b>A group of articles - web</b>	Grills and grill plates

1

#### All-stainless design

long life  
corrosion resistance of the top plate material

- savings on service interventions
- easier and faster operation

2

#### Degree of protection of the control elements IPX4

maintenance-free system  
resistance to splash water  
long life

- savings on service interventions
- easy cleaning and maintenance of equipment

3

#### Outlet for waste liquids

ensures that oil drips into the socket

- easy maintenance
- easy cleaning

4

#### High detachable hem

better hygienic conditions  
preventing grease from splashing onto ancillary equipment

- easy maintenance
- easy cleaning

5

#### Safety element - thermocouple

safe operation for personnel  
there is no overheating and damage to the thallus  
long life

- savings on service interventions
- easier and faster operation

# Technical data sheet



## Technical parameters

### Lava stone grill gas 2 cooking areas 2x 52x36 on open cabinet

<b>Model</b>	<b>SAP Code</b>	00110079
GL 70/80 G	<b>A group of articles - web</b>	Grills and grill plates

**1. SAP Code:**

00110079

**2. Net Width [mm]:**

800

**3. Net Depth [mm]:**

700

**4. Net Height [mm]:**

1004

**5. Net Weight [kg]:**

69.00

**6. Gross Width [mm]:**

860

**7. Gross depth [mm]:**

820

**8. Gross Height [mm]:**

1182

**9. Gross Weight [kg]:**

83.00

**10. Device type:**

Gas unit

**11. Construction type of device:**

With substructure

**12. Power gas [kW]:**

13.000

**13. Ignition:**

Piezo + večný plamen

**14. Type of gas:**

Natural gas, propane butane

**15. Protection of controls:**

IPX4

**16. Material:**

Stainless steel

**17. Griddle dimensions [mm x mm]:**

520 x 380

**18. Container for liquid fat:**

Yes

**19. Connection to a ball valve:**

1/2